



AIR

Frozen Beverage Machine



V-Air 2



Refrigerant gas R290



V-Air 3



FEATURES

- Product Options - In addition to traditional frozen beverages, V-AIR can serve dairy-based and alcohol-based products.
- Digital Control Board - Features an innovative digital display that indicates temperature of the beverage and machine settings at the touch of a button. very user friendly.
- Preventive Maintenance Reminder - The control board can signal the need for periodic maintenance on key components. Reduces downtime and ensures top performance.
- Zero Side Clearance Space - The Patented Ventilation Design allows for air to flow from front to rear, eliminating the need for any side clearance. Maximizes precious counter space.
- Front Hinged Lid - No need to remove the lid, simply lift to add product.
- Patented Quick Defrost Mode - 75% faster than thawing at room temperature to avoid long defrosting times.
- Large product hoppers hold 3.2 gallons (12L) each to maximize serving capacity.
- Drip Tray full indicator, user friendly.
- Fewer parts to clean and lubricate for PM
- Very easy access to remove filter from front for cleaning
- Extended Dispense Handle Sanitation listings NSF 18 and NSF 6 (Dairy)

Related Products & Accessories



Mixer
SL142-012883



Bowl
SL112-006271



Drip Tray
SL340000536

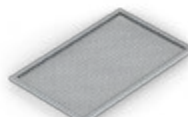

Filter
SL193-006174 (Double)
SL193-014231 (Triple)



P&P Tap
SL310005733



Seal Kit
SL310R1GE01



AIR

Frozen Beverage Machine



V-AIR 2

Twin bowl Frozen Beverage Machine with two 3.2 Gallon Bowl

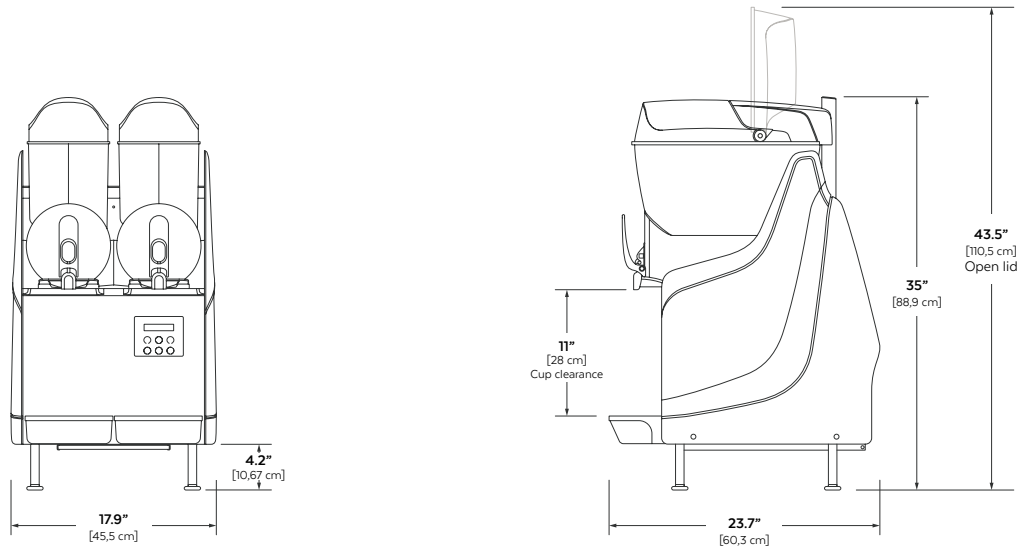

V-AIR 3

Triple bowl Frozen Beverage Machine with three 3.2 Gallon Bowl

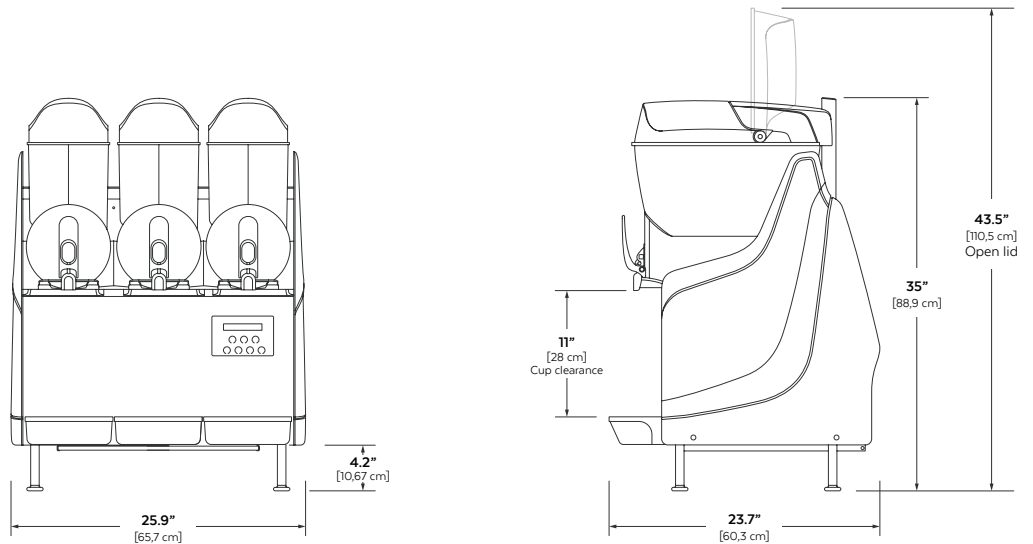

Specifications

MODEL	DESCRIPTION	CAPACITY	TAP CLEARANCE	DIMENSIONS	WEIGHT	SHIP DIMENSIONS
V-AIR 2	Twin bowl Frozen Beverage Machine	6.4 Gallons (2 x 3.2 Gal.) 24 Liters (2 x 12 L)	11 in 28 cm	35 x 17.9 x 23.7 in 88,9 x 45,5 x 60,3 cm	123.5 lbs. 56 Kg	37.8 x 20.5 x 24 in 96 x 52 x 61 cm
V-AIR 3	Triple bowl Frozen Beverage Machine	9.6 Gallons (3 x 3.2 Gal.) 36 Liters (3 x 12 L)	11 in 28 cm	35 x 25.9 x 23.7 in 88,9 x 65,7 x 60,3 cm	154.3 lbs 70 Kg	37.8 x 29.5 x 24 in 96 x 75 x 61 cm

Utility Requirements

MODEL	PHASE	VOLTS	AMPS	WIRE	WATTS	HERTZ
V-AIR 2	1 PH	115 V	9.6 A	2W+G	1100 W	50/60 Hz
V-AIR 3	1 PH	115 V	10.8 A	2W+G	1250 W	50/60 Hz

WARNING: This product can expose you to chemicals including Bisphenol A (BPA), which is known to the State of California to cause birth defects or other reproductive harm. For more information go to www.P65Warnings.ca.gov