

# Granitime Slush & Granita Machine



GT 2



GT 1



GT 3



Refrigerant gas  
**R290**



## FEATURES

- Push&Pull tap. Clean it without dismantle.
- Asymmetric bowls to ensure better mixing
- LED lightened cover with safety lock system
- Standby Mode
- Fast Freeze
- Drip Tray full Indicator
- Large, 3.0 Gallon Bowl Capacity
- Easy to Clean

## Related Products & Accessories



Mixer  
SL142-007129



Drip Tray  
SL340000536



P&P Tap  
SL310005733



Bowl  
SL310006937



Lid  
SL310007407



Seal Kit  
SL310RIGN01

## GT 1

Single bowl Frozen Beverage Machine with one 3.2 Gallon Bowl

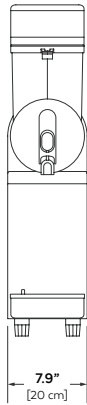

## GT 2

Twin bowl Frozen Beverage Machine with two 3.2 Gallon Bowl

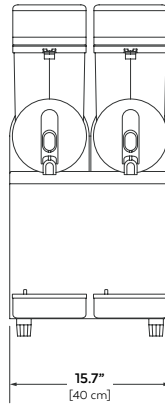

## GT 3

Triple bowl Frozen Beverage Machine with three 3.2 Gallon Bowl

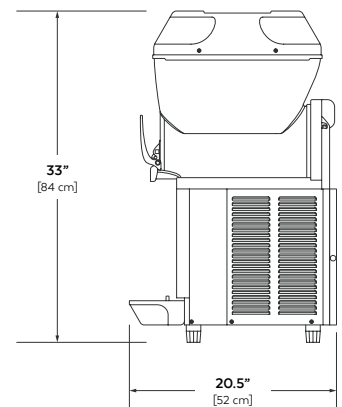
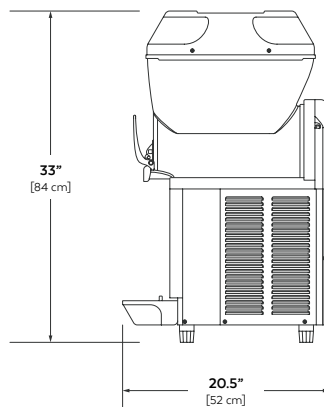
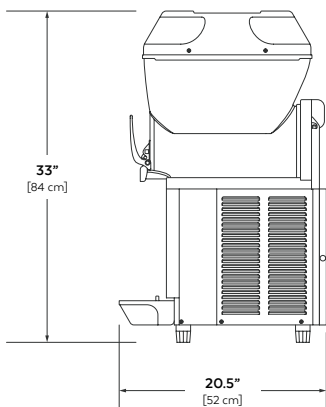
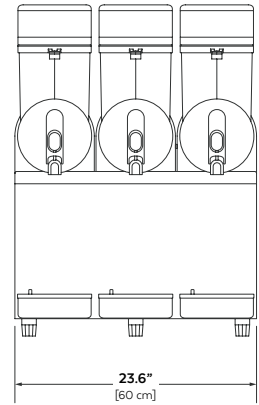

## Specifications

MODEL	DESCRIPTION	CAPACITY	TAP CLEARANCE	DIMENSIONS	WEIGHT	SHIP DIMENSIONS
GT 1	Single bowl Frozen Beverage Machine	3 Gallons (1 x 3 Gal.) 11,3 Liters (1 x 11,3 L.)	11.4 in 29 cm	33 x 7.9 x 20.5 in 84 x 20 x 52 cm	64 lbs. 29 Kg	38.2 x 10.7 x 24 in 97 x 27 x 61 cm
GT 2	Twin bowl Frozen Beverage Machine	6 Gallons (2 x 3 Gal.) 24 Liters (2 x 11,3 L.)	11.4 in 29 cm	33 x 15.7 x 20.5 in 84 x 40 x 52 cm	123.5 lbs 56 Kg	38.2 x 17.9 x 20.9 in 97 x 27 x 53 cm
GT 3	Triple bowl Frozen Beverage Machine	9 Gallons (3 x 3 Gal.) 36 Liters (3 x 11,3 L.)	11.4 in 29 cm	33 x 23.6 x 20.5 in 84 x 60 x 52 cm	154.3 lbs 70 Kg	38.2 x 25.7 x 22.7 in 97 x 65.3 x 57.7 cm

## Utility Requirements

MODEL	PHASE	VOLTS	AMPS	WIRE	WATTS	HERTZ
GT 1	1 PH	115 V	4 A	2W+G	450 W	50/60 Hz
GT 2	1 PH	115 V	9 A	2W+G	1000 W	50/60 Hz
GT 3	1 PH	115 V	11 A	2W+G	1200 W	50/60 Hz

WARNING: This product can expose you to chemicals including Bisphenol A (BPA), which is known to the State of California to cause birth defects or other reproductive harm. For more information go to [www.P65Warnings.ca.gov](http://www.P65Warnings.ca.gov)