

Diva

Gelato Plus



H 49 1/2 [H125] • 55 7/16 [H140]
 L 46 5/16 [120] • 65 25/32 [170] • 85 9/32 [220]







H 140

Installation	Plug-in	●
	Remote	□
Refrigerant	R290	●
Configuration	Channeling	□
	Dual temperature	□
Lighting	Led 5700 K	●
Refrigeration	Ventilated	●
Climatic class	7	●
Operator side closure	Plexiglass sliding doors	●
	Self rolling curtain	□
Control panel	Electronic	●
Work top	Solid surface white	●
Equipment handling	Swivel casters with brake and height adjustable feet	●

● Standard □ Special order

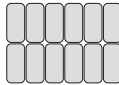
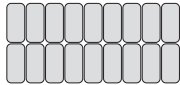
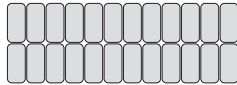
Colors	Side panels	Front panel	Grid
Corian™ Glacier White 	●	●	
RAL 9003 White 			●
Corian™ Clay 	□	□	
Corian™ Pearl Gray 	□	□	
Corian™ Bisque 	□	□	
RAL on request 	□	□	□

● Standard □ Special order

Configuration	120	170	220
Stainless steel containers Not included			
Standard 14 3/16 x 6 1/2 x 4 23/32H 	12 	18 	24 
5 lt Large 14 3/16 x 9 27/32 x 3 2/32H 	8 	12 	16 

External dimensions	Lenght	inch		46 5/16	65 25/32	85 9/32
Capacity	Gross / Net	liters	H 125	719 / 147	1059 / 216	1399 / 285
			H 140	865 / 147	1273 / 216	1680 / 285
Weight	Net	lb	H 125	661,4	826,7	1.036,2
			H 140	716,5	848,7	1.058,2
Climate class				7		
Operating conditions		°F / %RH [°C / %RH]		95 / 75 [35 / 75]		
Cabinet capacity range		°F [°C]		-4 / 35,6 [-20 / +2]		
Product temperature		°F [°C]		3,2 / 6,8 [-16 / -14]		
Refrigerant				R290		
Compressor	Type / Q.ty			Hermetic / 1	Hermetics / 2	
Defrost				Reverse cycle		

Electrical data

Technical info refers to models with built-in air cooled condensing unit

Power supply			220 V / 1 Ph / 60 Hz		
Nema plug			6-15P	6-20P	
Electrical input	A		7,1	13,6	14,1

Packaging

Type			Pallet + Carton			
External dimensions	Lenght	inch	54 11/32	73 13/16	93 5/16	
	Depth x Height	inch	53 17/32 x 61 11/16			
Gross weight	Gross	lb	H 125	705,5	881,8	1.102,3
			H 140	760,6	903,8	1.124,3

H 125

H 140

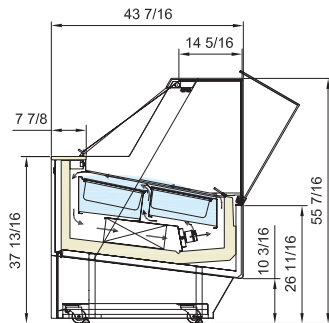
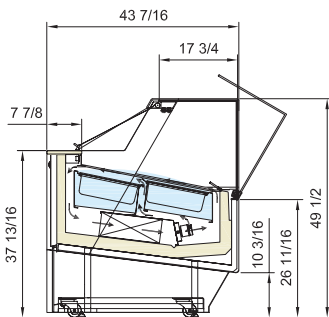

PLUS

Single evaporator with double front air out flow.
Fixed deflectors.



JTB Distributors
61 Sheey Ct Napa CA 94558
707-251-3910
info@jtbdistributors.com
www.jtbdistributors.com



Dealer